

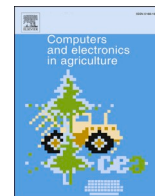

Contents lists available at ScienceDirect

Computers and Electronics in Agriculture

journal homepage: www.elsevier.com/locate/compag

Original papers

Multipurpose simulation model for pasture-based mobile AMS and milk marketing system, Part-I: Pasture, milk yield, and milk marketing characteristics

Techane Bosona^{*}, Girma Gebresenbet

Energy and Technology Department, Swedish University of Agricultural Sciences, P.O. Box 75651 Uppsala, Sweden

ARTICLE INFO

Keywords:

Mobile automated milking system
Grazing management
Milking frequency
Milk vending machine
Matlab Simulink
Multipurpose simulation model

ABSTRACT

It is essential to promote sustainable dairy farming which could lead to improved animal welfare, economic benefits, biodiversity and environmental benefits, milk quality, and customer satisfaction. In this regard, a mobile automated milking system (AMS) could contribute a lot. However, mobile AMS is a new innovative system which is not investigated well. Therefore, a simplified and integrated management approach should be introduced. The main objective of this study was to develop a multipurpose simulation model (DigiMilk model) specific to pasture-based mobile AMS. The model comprises five major subsystems: Pasture yield as dry matter (DM) and grazing characteristics; AMS Milking and milk yield characteristics; Milk handling and marketing; Resource consumption; and Economic assessment. This paper (Part-I) focuses on the first three components while the remaining two subsystems would be addressed in Part-II of this paper. DigiMilk model was built in MATLAB-Simulink environment. It was tested and evaluated using mainly secondary data and limited primary information acquired from a dairy farm in central Sweden. In this initial analysis, a continuous stocking system on pasture was assumed to be implemented from May 15 till September 15. Multiple sensitivity analyses were successfully conducted to get more insights. The results indicated that, considering maximum pasture growth rate of 77 kgDM day⁻¹ha⁻¹, the accumulated average pasture yield, over the grazing season, was estimated to be 6928 kgDM ha⁻¹. For cows with average grazing rate of 16–18 kgDM day⁻¹cow⁻¹, the stocking rate of 3 cow ha⁻¹ could lead to good performance of grazing management. When stocking rate and grazing rate of 3 cow ha⁻¹ and 16 kgDM day⁻¹cow⁻¹ were considered respectively, the cumulative milk yield values (excluding amount consumed by calves) over the grazing season were estimated to be 2101 L cow⁻¹ and 6303 L ha⁻¹. Out of this 6303 L ha⁻¹, 2952 L ha⁻¹ was estimated to be sold on-site, using milk vending machine (MVM), while 3351 L ha⁻¹ was to be delivered to super market. The accuracy of results from the the simulation model could be improved with future work with more real data from actual demonstration of mobile AMS over the entire grazing season. In addition to its capacity to serve as an integrated decision making tool, DigiMilk model enables to have organized digital data that could be useful for future researches to evaluate the environmental and/or economic performances of pasture-based dairy systems with mobile AMS.

1. Introduction

Conventional milking system (CMS) is more labour intensive in dairy farms (Bach and Cabrera, 2017). In CMS, there are about 600–900 milkings per cow annually (Shortall et al., 2016) which require a large amount of labour. Introducing Automatic milking system (AMS) reduces labour demand and the related cost. AMS appeared as commercial system in 1992 and relatively a recent development in dairy systems (Bach and Cabrera, 2017; Rodenburg, 2017). Nowadays, the application of

AMS is increasing in dairy farms due to potential benefits such as: reduction of labour demand; improved lifestyle of farmers; possibilities to increase milking frequency (MF) and milk yield, assign different MFs to different cows, and feed cows according to their individual nutrient needs as well as related feed composition (Shortall et al, 2016; Rodenburg, 2017; Bach and Cabrera, 2017).

Challenges related to application of AMS have also been reported recently. Some of the challenges are (Bach and Cabrera, 2017): difficulty in maintaining constant MF which could result in milk loss; excess

^{*} Corresponding author.

E-mail address: techane.bosona@slu.se (T. Bosona).

<https://doi.org/10.1016/j.compag.2021.106212>

Received 16 August 2020; Received in revised form 20 April 2021; Accepted 10 May 2021

0168-1699/© 2021 The Author(s). Published by Elsevier B.V. This is an open access article under the CC BY-NC-ND license

(<http://creativecommons.org/licenses/by-nc-nd/4.0/>).

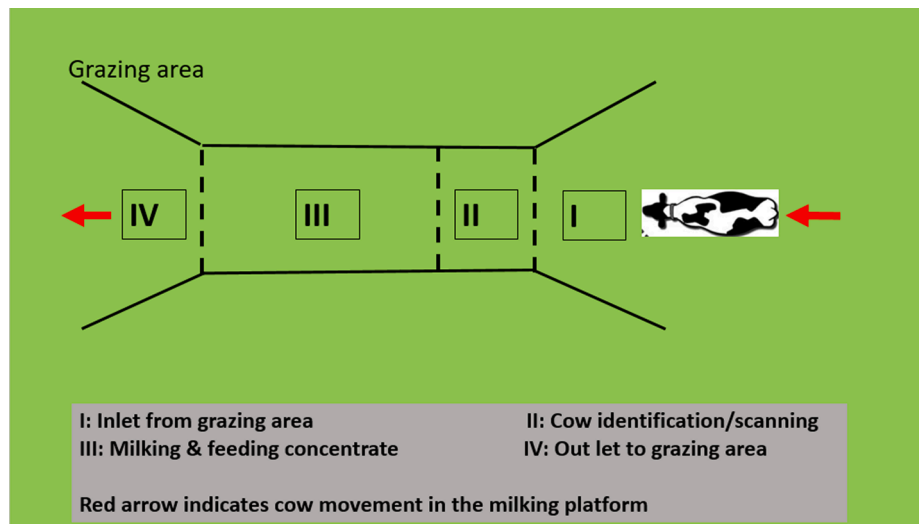

Fig. 1. Schematic illustration of cow movement through AMS-based milking facility. Source (Modified from Cooper and Parsons, 1999).

feeding of concentrate which could affect the energy intake and limit milking performance; and increase in capital cost per unit of milk yield. There is also a challenge of integrating AMS with grazing system.

1.1. Pasture-based AMS

Under natural circumstances, cows prefer to be at pasture field (Kerrisk, 2010). Pasture based AMS could be a feasible alternative and has benefits such as: reduction in labour demand and feed cost, increased biodiversity and sustainability, improved milk quality, better price of milk for farmers, animal health, and consumers satisfaction (Shortall et al., 2016). One of the challenges is the difficulty to get enough forage within appropriate distance i.e. about 1 km radius from milking facility (Stelwagen, 2001; Islam et al 2015). This increases the walking distance of cows which in turn reduces MF and milk yield. That means, pasture-based dairy with AMS at a fixed facility could not be effective at higher MFs (Stelwagen, 2001). Therefore, introducing a mobile AMS could be one of innovative solutions. Pasture yield, access time and distance to pasture, number of cow fetching per day, planned and achieved milking interval, MF, and milk yield are important parameters needed to be studied further in the pasture-based AMS dairy farms (Lyons et al., 2014).

1.2. Alternative milk marketing via milk vending machine

A Mobile AMS at grazing field could be integrated with a milk vending machine (MVM) for milk marketing. In the milk marketing chain, dairy processors and retailers have more power than farmers in Europe. On the other hand, milk consumption is decreasing in developed countries (Doležalova et al., 2014). To overcome these challenges, well managed MVMs could play an important role. Especially, small farms could be benefited from MVMs, because these farmers are often offered low price by milk processors due to costly logistics activities of milk collection from small farms. MVMs could help to diversify milk selling options (Doležalova et al., 2014), and thus raw milk and pasteurized milk could be supplied via MVMs. Logistic problems related to milk collection (from small farms), the need to diversify milk selling channels, and high profit and moral satisfaction for farmers are some of driving factors for implementing MVMs (Doležalova et al., 2014). It also increases the linkage between producers and consumers of ecological milk. In the current study, the option of selling milk via MVM to local customers has been included.

1.3. Digital data and modelling in dairy system

As agriculture is becoming data-driven industry, effective use of agricultural data is important (Drewry et al., 2019). Some of emerging technologies such as Cloud Computing, Big Data Analysis, Internet of Things, and Robotics enable digital transformation of agriculture and food supply chain sectors (Agrawal and Narain, 2018). Drewry et al. (2019) discussed areas of digital application adoption in farms such as finance and marketing tools and apps, sensor applications (e.g. in livestock), and robotic milking equipment.

In case of dairy farm, data-driven approach could lead to more accurate predictive information and more efficient use of resources such as pasture, energy, water, and labour. In this regard, developing effective and efficient data management leads to great success of dairy farming (Schuetz et al., 2018).

AMS facilitates the use of digital data for management as well as identifying cow health and welfare related information (Tse et al., 2018; Smith, 2020). However, more studies are required to understand how cows are interacting with the machines, as well as how the data is captured, stored, and processed (Smith, 2020). This could create the opportunity for data economy usefulness for sustainable development of dairy farms (Tse et al., 2018).

Even though, improvement in AMS technology is noticed, more research information is needed to identify research priorities. For this, digitizing and modelling tool is essential. On the other hand, modelling systems for grazing management is a challenge worldwide (Ruelle et al., 2015). However, there are modelling efforts to evaluate dairy farm related systems considering specific conditions of study area and farm. Example, Ruelle et al (2015) used a herd dynamic milk model integrating with a grazing management. Cooper and Parsons (1999) developed a discrete simulation model to evaluate AMS in UK that could simulate milk yield and cow's movement. Some studies (Cooper and Parsons, 1999; Shortall et al., 2016; Islam et al., 2015) have been conducted to evaluate economic effectiveness of AMS systems using different assumptions. But, there is a lack of studies that focus on mobile AMS. In the current study, we studied the case of a mobile AMS based on different assumptions and available secondary and primary data.

1.4. Objectives

The main objective of this study was to develop a multipurpose simulation model (DigiMilk) specific to a pasture-based mobile AMS. The model enables to investigate the characteristics of pasture yield and grazing; MFs and milk yield; alternative milk marketing chains; resource



Fig. 2. Milking by AMS of model DeLaval VMS™ (SLU, 2017).

demand for Mobile AMS operations; and economic performance of the dairy system with mobile AMS. This paper deals with the following specific objectives:

- to describe the characteristics of pasture yield and grazing, milking and milk yield, and milk marketing directly from the field
- to develop, and test the multipurpose simulation model with available data for a pasture-based mobile AMS at a Swedish dairy farm.

The detailed assessment of resource demand and economic assessment subsystems will be described in part-II of this paper. In general, DigiMilk model could be used as a basis for development of a decision support tool for farmers implementing and managing pasture-based mobile AMS dairy system.

2. Material and methods

2.1. Material and study area

2.1.1. Study area and mobile AMS facility

The dairy farm considered in this study was owned by a Swedish Livestock Research Centre at Lövsta, located in the central Sweden, in

Uppsala County. The centre has pasture field for grazing during May to September. In the housed dairy system, this farm uses milking rotary parlour (DeLaval AMR™) and automatic milking system (DeLaval VMS™) (SLU, 2017). For this study, it was assumed that an AMS with specific model DeLaval VMS™ could be installed in a “container” so that it could be mobile and used for milking cows at grazing field. This AMS model has a capacity of milking about 3400 kg milk daily (DeLaval, 2018).

The mobile AMS facility to be implemented is conceptually illustrated in Fig. 1. There are four major sections: (I) Cow leaves the grazing area and leads to entrance of milking unit; (II) cow enters into identification area to be allowed or denied access to milking unit depending on time length since the last milking; (III) area for milking and feeding supplement feed; and (IV) the cow leaves the milking area and goes back to grazing field.

Major activities to be performed in AMS include: positioning of cows for milking and providing supplement feed; pre-spray, cleaning and stimulation of teats; attaching teat cups and performing milking; final spray of teats; and cleaning teat cups and floor (SLU, 2017). The milking process with AMS is depicted in Fig. 2. The milking duration (total time elapsed to complete a single milking process) could be up to 8 min.

2.1.2. Dairy cows

At the Lövsta dairy farm, in housed system, there were about 280 Swedish Red and Holstein cows out of which about 96% were lactating (SLU, 2017). In this case, a single AMS VMS™ could serve 60–65 cows. For the application of a pasture-based mobile AMS, it was assumed that up to 16 lactating cows could be milked on the grazing field. However, detailed simulation analyses were done at two levels: single cow and a hectare of grazing area. A cow-calf-together practice was also assumed. The exact number of cows to be milked on grazing field could be determined only if demonstration with full capacity is conducted. This in turn depends on the available grazing field, and related resource demands such as energy and water supply on the field.

2.1.3. Milk vending machine

An automatic MVM was assumed to be installed (Fig. 3a). From the commercial website of Alibaba (Alibaba, 2020a), the specific MVM has power rate of 350 W with power source of AC115-240 V. It has a size of 0.1 m, 0.8 m, 1.97 m i.e. width, length, and height respectively. It has two milk tanks with volume capacity of 75 L each and water tank with capacity of 10 L. It dispenses 12 L of milk per minute while about 3 s is



Fig. 3. (a) Automatic fresh milk vending machine, (b) and small milk pasteurizer, (Alibaba, 2020a; Alibaba, 2020b).

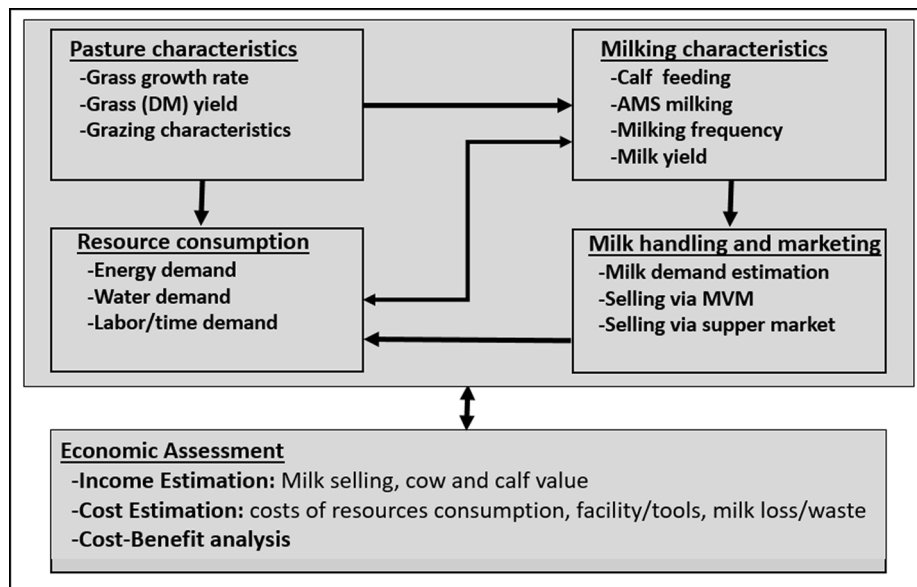

Fig. 4. A brief conceptual illustration of the DigiMilk model with the main subsystems and their connection. The detail work of Resource Consumption and Economic Assessment subsystems are not included in this paper.

Table 1

Summary of main parameters with estimated value used in the modelling process.

Parameter	Description	Unit	Estimated value ^(SD)	Reference
Y_{max}	Maximum accumulated pasture yield	kgDM ha ⁻¹	8000(941)	Extracted from Frankow-Lindberg (1989)
G_{max}	Maximum pasture growth rate	kgDM day ⁻¹ ha ⁻¹	77(7.71)	Frankow-Lindberg (1989)
Y_{opt}	Cumulative pasture mass at time when G_{max} attained	kgDM ha ⁻¹	2850(409)	
k	Grass growth parameter	Dimensionless	-3.478	Calculated
r	"	Dimensionless	1.288	
R	"	dimensionless	0.272	
w	"	day ⁻¹	0.0354	
B	"	day ^{-k}	$8.5 * 10^6$	
t	Pasture growing time	day	1-168	From April 1st till September 15th
T_z	Grazing duration	day	1-123	From May 15th till September 15th
S_r	Stocking rate	Cow ha ⁻¹	3(1.34)	Expert estimation
Z_r	Grazing rate	kgDM ha ⁻¹ cow ⁻¹	10-18	Expert estimation

SD_values in the bracket represent standard deviations.

required per washing the machine. That means if there is milk demand and the machine is used for effective 1 h, about 720 L of milk can be sold using a single MVM. In this study, only one MVM was considered to be installed in the grazing field to serve local consumers.

2.1.4. Milk pasteurizer

It was assumed that a small milk pasteurizer could be used in this system (see Fig. 3b). This assumption was made based on the fact that only 16 lactating cows were assumed to be milked with the mobile AMS. Accordingly, a small pasteurizer with dimension of 0.8 m (width), 1.9 m

(length), 1.9 m (height); weight of 350 kg; and the sterilization efficiency of up to 1000 L per hour was considered based on the information from commercial site (Alibaba, 2020b).

2.1.5. Data and modelling environment

A MATLAB-Simulink, a graphical modelling and simulation environment, was used to develop the DigiMilk model. In this case, MATLAB R2019b version was used. Secondary data from peer reviewed and other reliable sources were widely used. Primary data and information have also been acquired from Livestock Research Centre (see Section 2.1.1).

2.2. System description and modelling

The conceptual description of the DigiMilk model is presented in Fig. 4. The model has components dealing with Pasture characteristics; AMS milking characteristics, Resources consumption, Milk marketing, and Economic assessment. The detail description of each component and respective Simulink block diagram have been presented in the next subsections. The detailed resources demand estimation and economic assessment studies will be reported in Part II of this paper.

2.2.1. Pasture yield and grazing characteristics

2.2.1.1. Pasture growth rate and yield. In the grazing management, improved management decision such as adjusting the stocking rate can be made if the quantity and quality of forage are well predicted (Ruelle et al., 2015). In this study, a simple sigmoid equation (see Eq.1.) was used to model and describe pasture growth characteristics based on the work of Cacho (1993). The equation enables to predict pasture growth under continuous grazing or grass cutting. For determining the parameters (see Table 1) that were used in the modelling, data of pasture yield and pasture growth rate, estimated for the situation of the study region under consideration, were extracted from Frankow-Lindberg (1989).

Pasture growth rate and yield depend mainly on the temperature and precipitation of the area and the use of fertilization (Frankow-Lindberg, 1989). The data was related to grass dominated pasture grown in central Sweden where mean monthly temperature (during April - September) varies from about 4°C (April) to 16°C (July) during 1984 to 1987 (Frankow-Lindberg, 1989). Similarly, precipitation in the area varies from 29 mm (April) to 71 mm (July). The pasture was fertilized field with nitrogen at the rate of about 200 kg ha⁻¹.

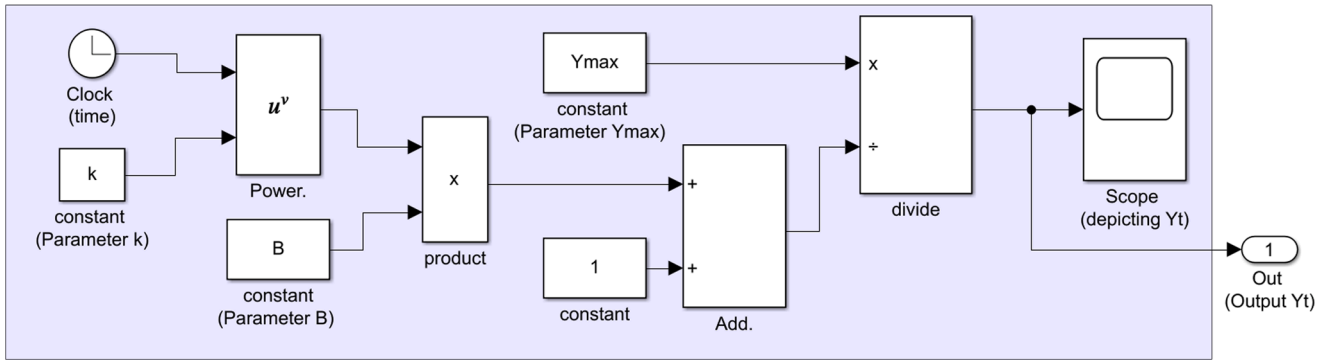

Fig. 5. Subsystem of Simulink model for pasture yield estimation. The parameters are as described in eq(1). “Clock”, “Constant”, “power”, “product”, “add”, “divide”, and “scope” are some of model building blocks in Simulink Library.

Major equations that were implemented in subsystem of Simulink model for grass yield and growth rate estimation were Eq(1) and Eq(6) respectively. Other equations were also used to determine estimated values of relevant parameters (see Eq(2)-Eq(5)).

$$Y_t = \frac{Y_{max}}{1 + (B^*t^k)} \quad (1)$$

Where Y_t is cumulative pasture yield at time t , expressed in kg DM ha⁻¹; t is time in days i.e. grass growing time starting from April 1 till September 15; and Y_{max} is maximum accumulated pasture yield in kg DM ha⁻¹ over the grass growing season.

k and B are grass growth parameters which could be estimated from Eq(2) and Eq(3).

$$k = \frac{Y_{max}}{2Y_{opt} - Y_{max}} \quad (2)$$

Where Y_{opt} is the cumulative pasture mass in kg DM ha⁻¹ corresponding to the maximum pasture growth rate, G_{max} (Cacho, 1993). Y_{opt} , G_{max} , and Y_{max} were estimated from data recorded by Frankow-Lindberg (1989). Firstly, the recorded values of growth rate and pasture yield at a given time were drawn as illustrated in Appendixes A1 and A2. Secondly, important parameters such as Y_{opt} , G_{max} , and Y_{max} were determined and used in the main simulation model. The study made by Frankow-Lindberg (1989) was conducted in Sweden where the current study focused and some of the data were extracted from their work. The main parameters were estimated based on recorded data or determined using equations have been provided in Table 1.

$$r = \frac{k - 1}{k} \quad (3)$$

$$R = (1 - \frac{r}{2})^{2*} \left(\frac{2}{2-r} - 1 \right)^r \quad (4)$$

$$w = -k*B^{\frac{1}{k}} \quad (5a)$$

$$w = \frac{G_{max}}{R*Y_{max}} \quad (5b)$$

The average pasture growth rate (G) at time t was then modelled using Eq(6)

$$G = w \frac{Y_t^2}{Y_{max}} \left(\frac{Y_{max} - Y_t}{Y_t} \right)^r \quad (6)$$

Where, B , k , and r are parameters related to grass growing. In order to reflect the characteristics of data from grazing experiments, the values of some parameters were kept within defined range: $B > 0$; $1 < r < 2$; and $k < -1$. r is a dimensionless parameter while w has a unit of time⁻¹. The detailed explanations of the Sigmoid equation and related parameters have been provided in Cacho (1993). The schematic illustration of Simulink model subsystems for estimation of pasture yield and grass growing rate are depicted in Figs. 5 and 6.

2.2.1.2. Grazing characteristics. Grazing could be on cultivated pasture and/or natural pasture (SLU, 2017). Grass availability, grass quality,

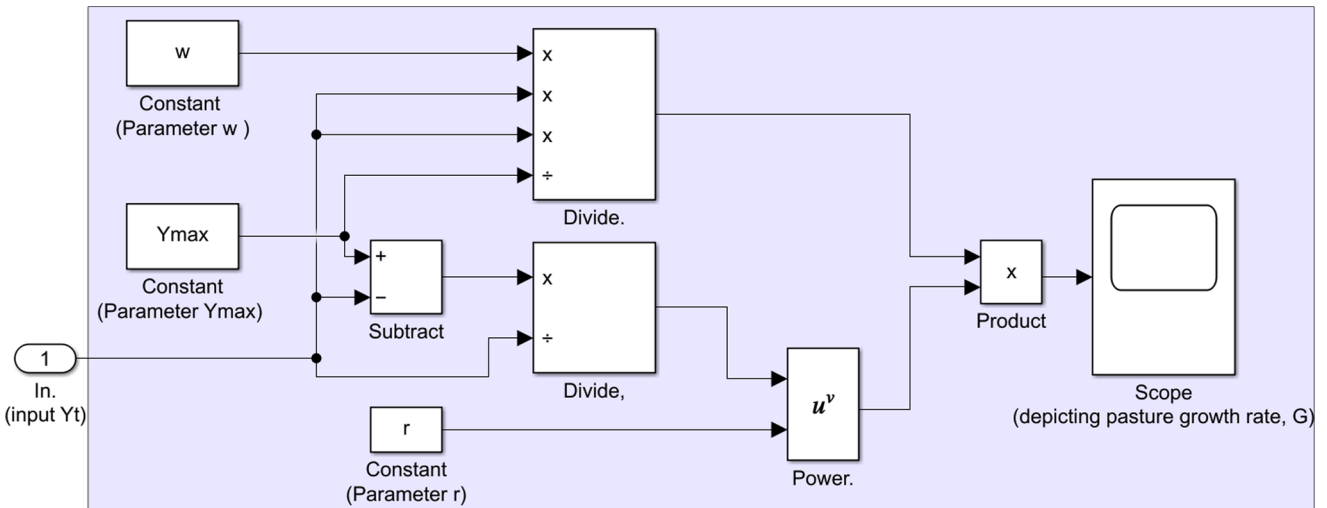

Fig. 6. Subsystem of Simulink model for determining Pasture growth rate.

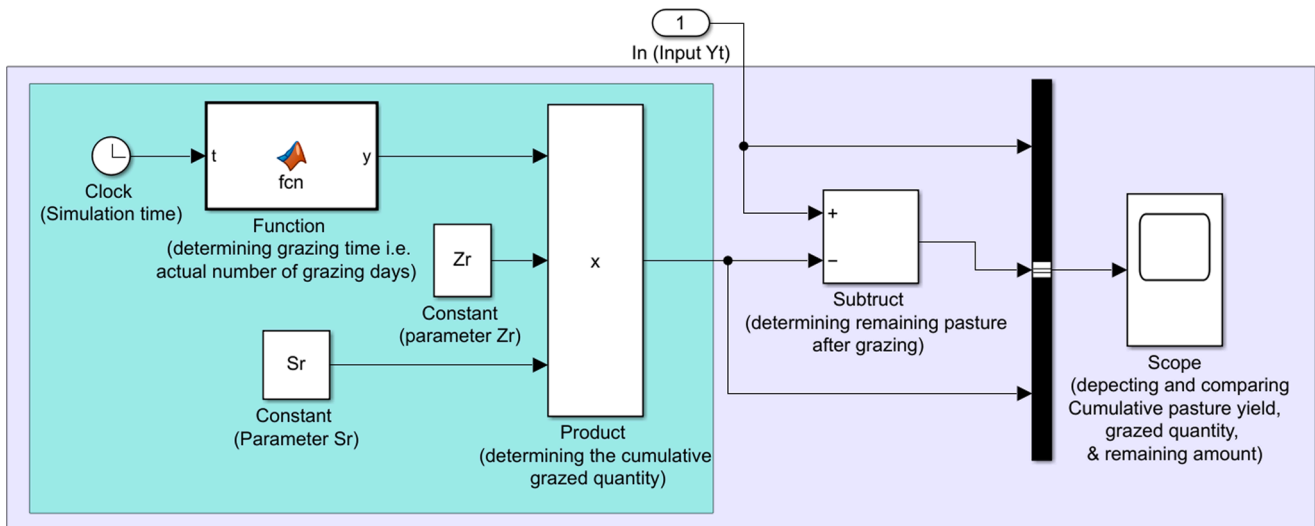

Fig. 7. Subsystem of Simulink model for estimation of grazed quantity and remaining pasture.

cow characteristics, and the interactions between animal and the grass determine the grazing rate of cow (Ruelle et al., 2015). According to the 1987 pasture legislation of Sweden, Uppsala County is the region where cows must stay at pasture at least 3 months, during April 1 to October 31. In such case, at least for two months between May 15 and September 15, cows should be at pasture continuously. In this modelling, it was assumed that cows could be at pasture continuously from May 15 till September 15.

Cumulative quantity of grazed grass depends on stocking rate (S_r), grazing rate (Z_r) and length of grazing season. It was modelled as indicated in eq (7).

$$G_{qh} = S_r * T_z * Z_r \quad (7)$$

Where G_{qh} is cumulative grazed grass in kgDM ha^{-1} at a given time; Z_r is grazing rate in $\text{kgDM day}^{-1}\text{cow}^{-1}$; S_r is stocking rate in number of cows per hectare; T_z is grazing duration in number of days starting from first day of grazing. The grazing time starts from 45th day of pasture growing time t .

In a continuous stocking system, grass growing and grazing are continuous processes. The actual available pasture for grazing at a given time (AY_t) in kgDM ha^{-1} , could be estimated using Eq (8).

$$AY_t = Y_t - G_{qh} \quad (8)$$

The Simulink block diagram for estimation of grazed quantity and remaining pasture is given in Fig. 7.

In Table 1, the average values of Y_{\max} , G_{\max} , and Y_{opt} have been given along with standard deviation (SD) in the bracket. Other grass growth parameters were calculated based on values of Y_{\max} , G_{\max} , and Y_{opt} as indicated in the Table 1. Therefore, SD values included to address uncertainties associated with these parameters which could influence the other parameter values and simulation results. In addition, SD values has been indicated for S_r . When there is enough pasture, grazing duration in the study area could be extended till end of October i.e. from 123 days to 169 days.

2.2.1.3. Pasture quality parameters. Without supplemental feed, grazing cows consume less DM (Kolver and Muller, 1998). Therefore, supplementation is required to increase the DM intake and fulfil a balanced feeding requirement. However, optimizing the nutrition of grazing dairy cows is still a challenge. The nutrient intake of cows depends also on animal's live weight (Kolver and Muller, 1998). Pasture quality parameters such as dry matter (DM), organic matter (OM), crude protein (CP), digestibility coefficient of organic matter (VOS), neutral detergent

Table 2

Indicative values of pasture quality parameters specific to the study area.

Quality parameter	Unit	Average value
OM	% of kgDM	90.6*
CP	% of kgDM	12.8
NDF	% of kgDM	48.2
VOS	% of kgDM	86
ME	MJ kgDM^{-1}	10.8
Ash	% of kgDM	8.8

Source: Except OM, all data were extracted from the study by Guzhva (2013). The unit is in % of DM (pasture) intake. *-Adapted from Kolver and Muller (1998).

Table 3

Indicative values and relationship between dry matter (DM) intake and cow milk yield.

Description	Minimum value	Mean value	Maximum value	Reference
Housed condition				
Total feed intake (kgDM day^{-1}) ^a	10.5	19.1	26	Pang et al (2019)
Milk yield (L $\text{cow}^{-1}\text{day}^{-1}$) ^b	13.4	26.7	37.4	Pang et al (2019)
FMF (L kgDM^{-1})	1.28	1.4	1.44	Author's estimation ^d
Total feed intake (kgDM day^{-1}) ^a	16	22	28	Expert estimation
Milk yield (L $\text{cow}^{-1}\text{day}^{-1}$) ^b	30	40	50	Expert estimation
Feed-to-Milk yield factor (L kgDM^{-1})	1.88	1.82	1.78	Author's estimation ^d
Grazing condition				
Total feed intake (kgDM day^{-1}) ^c (including 3 kg $\text{cow}^{-1}\text{day}^{-1}$ concentrate during milking)	13	19	21	Expert estimation
Milk yield (L $\text{cow}^{-1}\text{day}^{-1}$) ^b	16	25	36	Expert estimation
FMF (L kgDM^{-1})	1.23	1.32	1.71	Author's estimation

a-feeding condition with 60% silage (grass) and 40% supplement, this is in housed condition; b-in Pang et al (2019) the unit was in kg of milk (and considered to be equal to a litre of milk); c-estimated for grazing condition (natural field case). d-own estimation and referring to Albertamilk (2020).

Table 4
Indicative values of milk quality parameters.

Milk Quality parameter	Unit	Value
MF	Cow ha ⁻¹	2.24
MY	Kg cow ⁻¹ day ⁻¹	33.9
ECM	Kg cow ⁻¹ day ⁻¹	33.7
Milk Fat	% (of milk yield)	3.8
Milk Protien	%	3.44
Milk Lactose	%	4.79

Source: Extracted from Guvhva (2013).

fiber (NDF), and metabolizable energy (ME) are important in pasture-based dairy management. Table 2 presents the indicative pasture quality parameter values extracted from the study by Guzhva (2013) which was conducted at the same study area using the dairy farm at Lövsta (SLU, 2017). The study made by Guzhva (2013) was based on pasture field with grass-to-clover proportion of 50:50, stocking rate of 3 cows ha⁻¹, and 10 h grazing duration per day. The pasture quality characteristics (see Table 2) were taken into consideration when FMF values indicated in Table 3 were estimated.

In addition to pasture with quality characteristics indicated in Table 2, a concentrate feed with quality parameters NDF, CP, and ME of

302 g kgDM⁻¹, 182 g kgDM⁻¹, and 132 MJ kgDM⁻¹ of concentrate feed was provided (Guzhva, 2013).

2.2.2. AMS based milking, milk yield, and quality

MF is one of factors that influences the dairy farm management. Although it could vary from 1 to 6 times per day, the mostly practiced MF in the world is twice daily milking (Stelwagen et al., 2013; Hart et al., 2013). In this study, a thrice-daily MF is considered as basic scenario and supported with sensitivity analyses.

Milk yield estimation could be done on udder or teat (a quarter udder) basis (SLU, 2017). This represents the total milk yield which includes milk consumption by calf, milk loss during milking process, and amount milked. Milk yield also depends on the quality and quantity of feed intake.

When compared with the house-based dairy system, natural field (pasture-based) dairy system produces less milk yield, with a reduction up to 50% (Albertamilk, 2020; Pang et al., 2019; Communication with expert). Table 3 presents important estimated values of feed intake and milk yield. In the modelling to estimate milk yield, a feed-to-milk factor (FMF) of 1.23–1.71 L/kg DM was considered as average value for the continuous grazing condition under consideration (see Table 3). The FMF values could vary depending on the quality and amount of DM

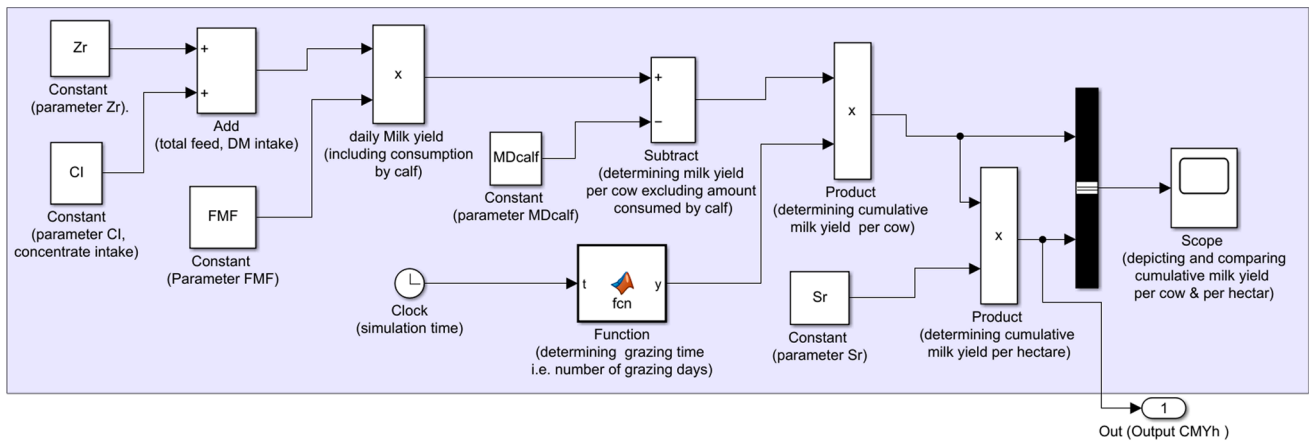

Fig. 8. Subsystem of Simulink model for determining daily and cumulative milk yield.

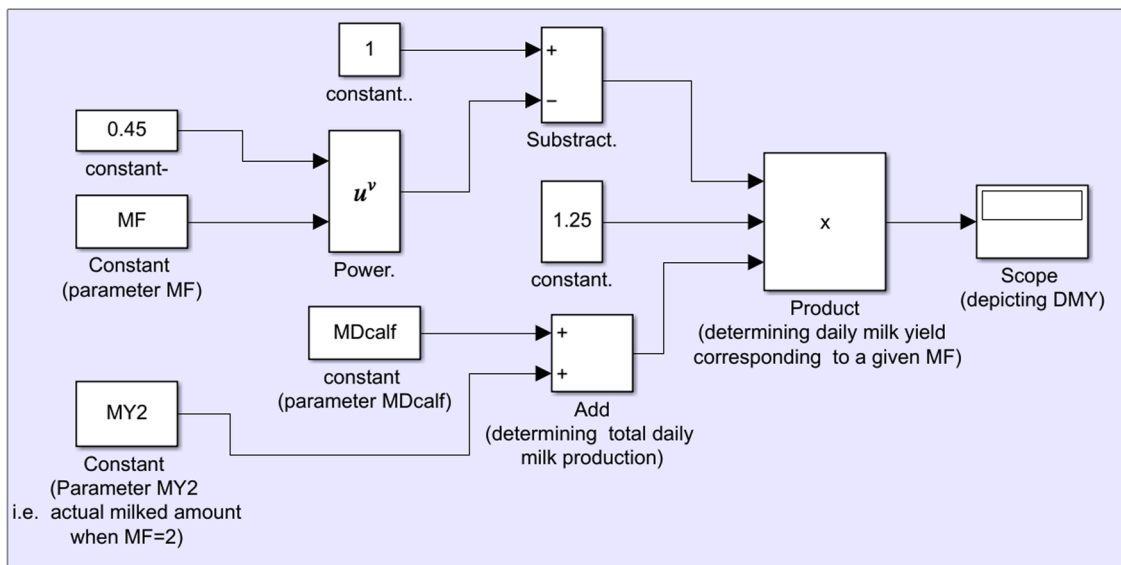

Fig. 9. Subsystem of Simulink model for investigating the influence of MF on milk yield using eq(10a) and eq(10b).

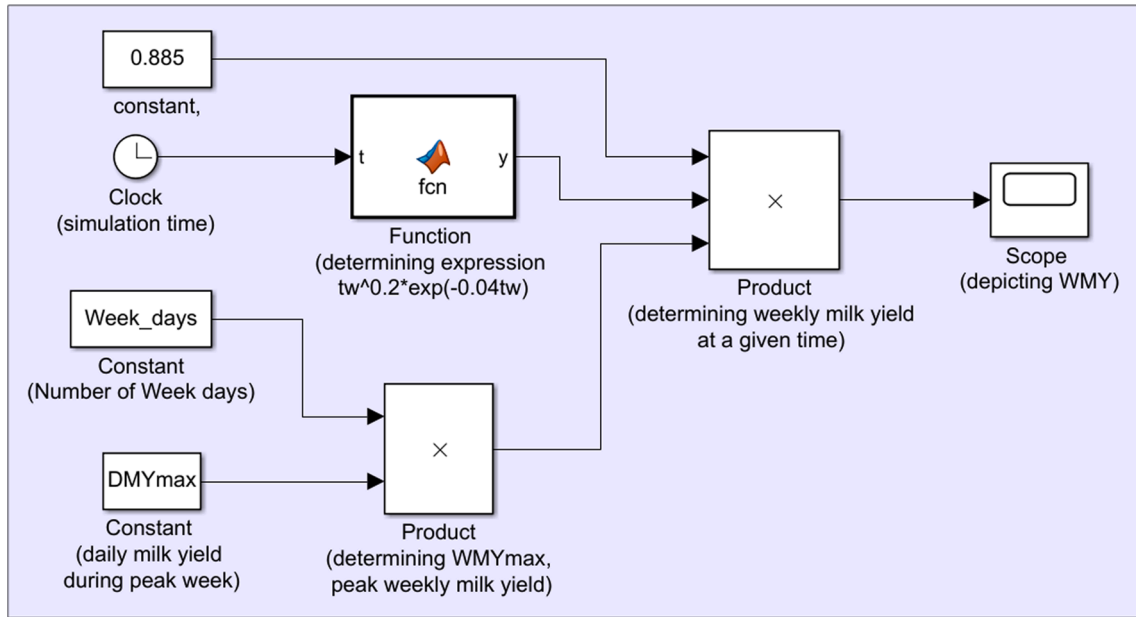

Fig.10. Subsystem of Simulink model for determining weekly milk production along the lactation period.

intake. In the study area, the FMF values indicated in Table 3 were estimated taking into consideration the pasture quality and pasture availability (see Table 2 and 3).

Regarding milk quality, the composition of milk is influenced by factors such as cow breed, feeding systems, seasonal changes, MF and milking systems (Lindmark-Månsson et al., 2003). In the study area, the milk quality parameters related to the pasture characteristics described in Table 2 are presented in Table 4.

Based on the information given in Tables 1 & 3, cumulative milk yield per hectare (CMY_h) along grazing season (Tz) with a given Sr , was modelled using Eq (9).

$$CMY_h = (FMF * (Z_r + CI) - MD_{calf}) * T_z * S_r \quad (9)$$

CMY_h in $L ha^{-1}$; Tz in days; Sr in $cow ha^{-1}$; Z_r in $kgDM day^{-1} cow^{-1}$; CI is concentrate intake in $kg day^{-1} cow^{-1}$ supplied during AMS milking. MD_{calf} is daily milk requirement for a calf, in $L day^{-1} cow^{-1}$ (see section 2.2.3.1). For basic, scenario, $FMF = 1.32 L kgDM^{-1}$ was considered. Fig. 8 presents Simulink model diagram for milk yield estimation per cow and hectare.

Feed intake and milk yield also vary along lactation period. To get the insight, the variation in milk yield in relation to MF and lactation period was modelled based on the work of Cooper and Parsons (1999). Accordingly, the daily milk yield (DMY) at a given MF could be modelled as indicated in Eq(10) (see Fig. 9).

$$DMY = 1.25 * (1 - 0.45^{MF}) * DMY_2 \quad (10a)$$

$$DMY_2 = MD_{calf} + MY_2 \quad (10b)$$

Where, DMY in $L day^{-1} cow^{-1}$; DMY_2 is daily milk production in $L day^{-1} cow^{-1}$ when MF is twice daily milking; MD_{calf} is daily consumption by a calf in $L day^{-1} cow^{-1}$; MY_2 is daily milk yield for marketing (or human consumption) in $L day^{-1}$.

Similarly, weekly milk yield was modelled as indicated in Eq(11).

$$WMY_c = 0.885 * (WMY_{max} * (t_w^{0.2}) * exp(-0.04t_w)) \quad (11)$$

Where, WMY_c is weekly milk yield in $L cow^{-1}$; WMY_{max} is weekly peak value in $L cow^{-1}$; t_w number of weeks starting from first week of lactation. During modelling in Simulink, the first week of April was assumed to be the first week of lactation (see Fig. 10).

2.2.3. Milk demand estimation and marketing

In order to model and simulate milk supply to market, milk demand by different groups of consumers should be reasonably predicted. In this study, milk demands have been categorized as calves' consumption, supply to local customers, supply to super market, and MLW along milk supply chain. Fig. 11 presents the conceptual illustration of milk flow along supply chain from a single grazing field to consumers. In case of multiple fields, milk could be collected to a defined milk collection

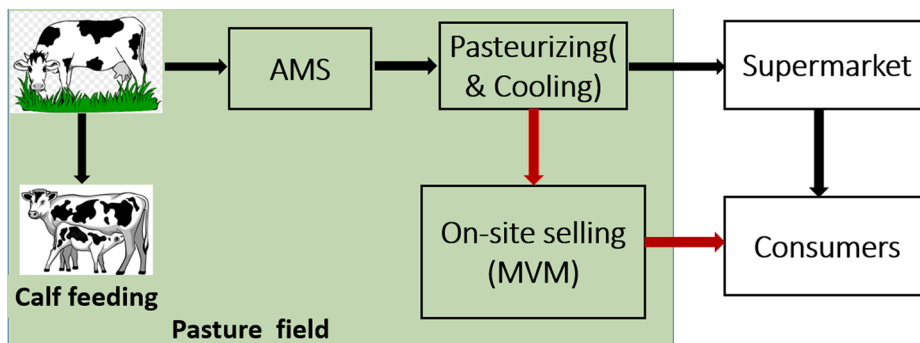

Fig.11. Conceptual map of milk flow along supply chain under consideration. Black arrow indicates milk marketing via supermarket.

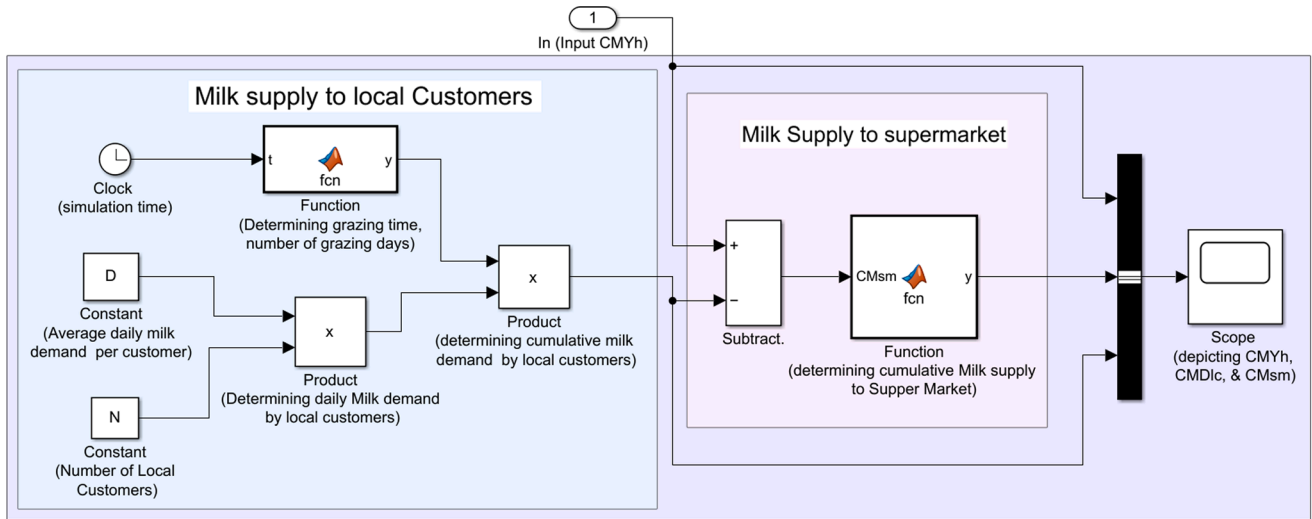

Fig. 12. Subsystem of Simulink model to determine milk demand by local customers and supermarket.

Table 5
Main parameters considered in sensitivity analysis.

Investigated (dependent) parameter	Independent (varying) parameter	Value range of independent parameter
Daily milk yield & cumulative milk yield	Grazing rate	10–18 kgDM cow ⁻¹ day ⁻¹
Daily milk yield	Milking frequency	1–6 milking cow ⁻¹
Weekly milk yield	Peak* milk yield	30–45 L cow ⁻¹ day ⁻¹

* -Daily milk yield during peak lactation week.

point. Fig. 12 presents the Simulink model subsystem for the assessment of milk demand and selling.

2.2.3.1. *Milk consumption by calves.* Milk is a complete diet for calves at their early stage and enough milk should be provided during the first 2 months (Stelwagen, 2001; personal communication with expert at Livestock Research Centre). In the house-based dairy case, each calf was fed twice a day. Each time, 2–2.5 L of milk is provided to each calf i.e. 4–5 L day⁻¹cow⁻¹. In this study, a calf-cow-together practice was considered with average value of daily milk demand by each calf (MD_{calf}) which was estimated to be about 7–8 L day⁻¹cow⁻¹.

2.2.3.2. *On-site milk selling via MVM.* It was assumed that local customers in the vicinity of grazing field, can purchase milk directly from MVM to be installed for on-site selling. The milk to be marketed via the MVM depends on the milk demand by the local customers and could be expressed using Eq (12) as:

$$MDlc = \sum_{n=1}^N D_n \quad (12)$$

$MDlc$ = daily milk demand by local customers in L day⁻¹; N = total number of local customers purchasing milk via MVM; D_n = milk demand by nth local customer in L day⁻¹.

2.2.3.3. *Milk delivery to supermarket.* After selling on-site, the remaining milk could be delivered to super market. Considering milk production at farm level (grazing field), the quantity of milk to be delivered to super market could be estimated using Eq (13):

$$Msm = N_c * (DMY - MD_{calf}) - MDlc \quad (13)$$

Where Msm is daily milk supply to super market in L day⁻¹; DMY is daily milk yield in L cow⁻¹day⁻¹. N_c is number of lactating cows in the field. If

milk demand to be purchased via MVM is not high, Msm could be estimated also at hectare level.

2.2.4. Sensitivity analysis

Sensitivity analysis enables to conduct what-if analysis especially where there is limitation of data, to investigate the future trends and understand the behaviour of complex systems (Golfarelli and Rizzi, 2009). This study was based on data mainly from secondary sources, personal communication and expert assumptions. Therefore, multiple sensitivity analyses have been conducted to get more insight at different subsystems of DigiMilk simulation model. Table 5 presents the main parameters considered in the sensitivity analyses.

2.2.5. Model evaluation

During model building, many simulation trials were run for each subsystem in order to test if the model performs or not according to the conceptual definition of DigiMilk model. Then, parameter based evaluation was conducted. In this case, there was no real data recorded at grazing field regarding parameters such as grass yield, animal intake, and milk yield from each cow. However, the simulation out puts were evaluated by controlling if the results were within the expected values or not. Accordingly, the model evaluation was done at different levels considering the major parameters: grass yield per hectare; grazing rate and total animal intake per cow and per hectare; quantity of grass grazed during the grazing season; daily milk yield per cow and per hectare; cumulative animal intake and milk yield; and local customers' milk demand over grazing season.

2.2.6. Limitation of the study

This study has limitations as it is based on literature-based data and many assumptions. There was limitation of actual data in this study. Mainly secondary data and limited information from dairy farm under consideration and expert estimation have been used in this study. For instance, if there is measured FMF value, it could improve the model performance in predicting milk yield. It should be noted also that the variability between animal and grazing area was not taken into account. It was assumed that the animal and grazing field are uniform. The actual lactation period of different cows varies during the grazing season. However, it was assumed that the lactation starts from first week of April for all the 3 cows allocated per hectare.

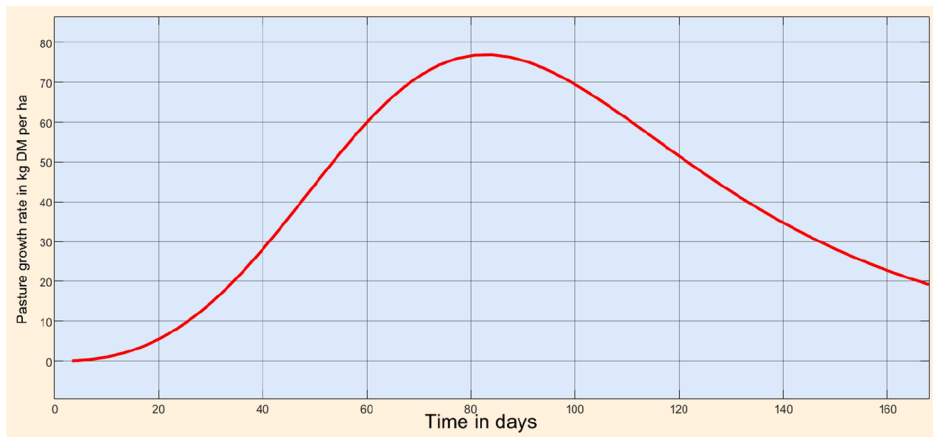

(a)

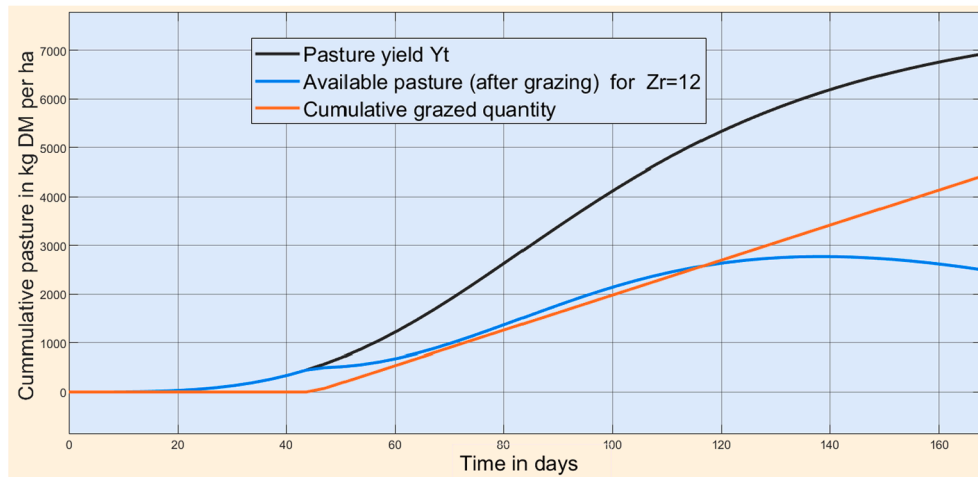

(b)

Fig. 13. (a) Simulated pasture growth rate and (b) Cumulative pasture quantity.

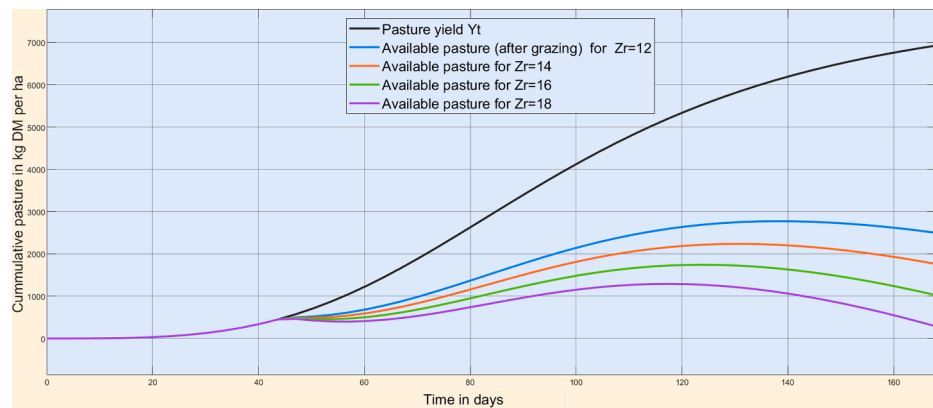

Fig. 14. Sensitivity analysis with $S_r = 3$ and varying Z_r .

3. Simulation results and discussion

3.1. Pasture yield and grazing characteristics

In the study area, grass grows slowly at the beginning of April month and the growing rate increases towards May month. After May, the growth rate decreases and at the end of grazing period, it was estimated to be about $20 \text{ kgDM day}^{-1}\text{ha}^{-1}$. Using Eq (6) and the parameter values indicated in Table1, the grass growth rate was simulated. The grass

growth rate, could also be modelled and simulated directly by defining dY_i/dt in Simulink. The G_{\max} value was $77 \text{ kgDM}^{-1}\text{day}^{-1}\text{ha}^{-1}$, which often occurs towards end of May.

Fig. 13 presents the simulated results of cumulative pasture yield, grazed quantity, and residual after grazing when grazing rate of 12 kgDM cow^{-1} and stocking rate of 3 cow ha^{-1} were considered. At the end of grazing period, the estimated pasture yield, grazed quantity and residual quantity were $6928 \text{ kgDM ha}^{-1}$, $4428 \text{ kgDM ha}^{-1}$, and $2500 \text{ kgDM ha}^{-1}$ respectively (see Fig. 13). From Fig. 13, it is possible to

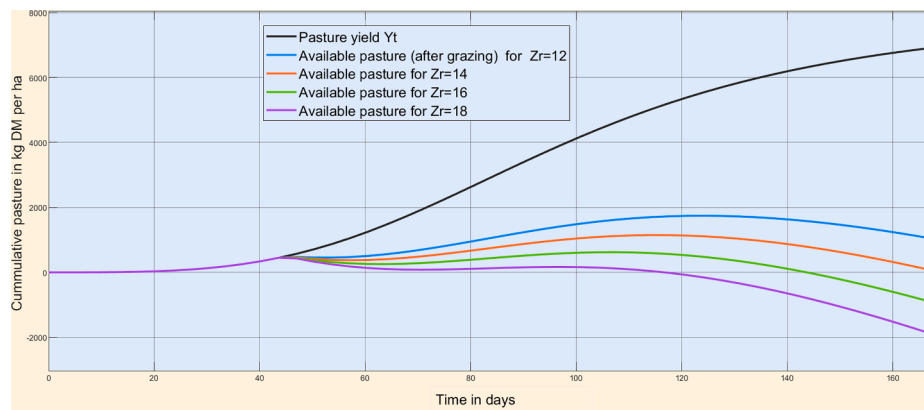

Fig. 15. Sensitivity analysis with $Sr = 4$ and varying Zr from 12 to 18 $\text{kgDM cow}^{-1}\text{day}^{-1}$.

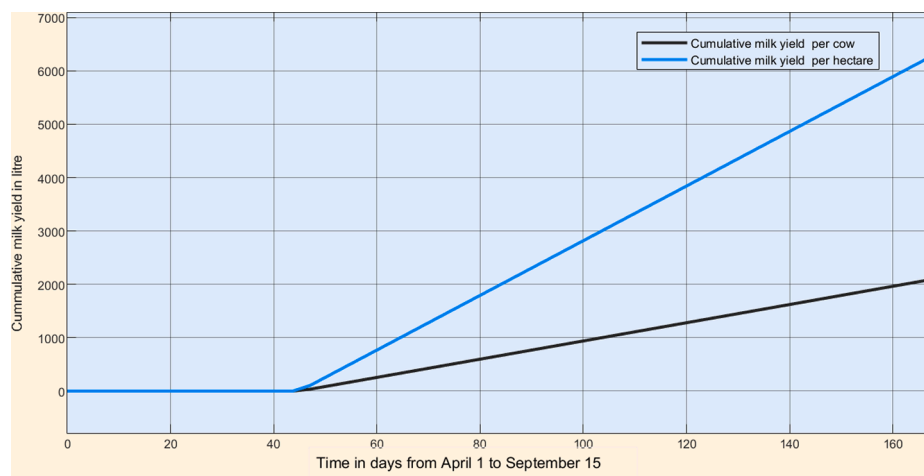

Fig. 16. Estimated cumulative milk yield (after reducing consumption by calf), considering $Zr = 16 \text{ kgDM cow}^{-1}$ and $Sr = 3 \text{ cows ha}^{-1}$.

notice that the grazing field could afford more than 3 cows per hectare. To investigate this in more details, sensitivity analysis was done (see Figs. 14 and 15).

Figs. 14 and 15 present the results of sensitivity analyses for stocking rate of 3 and 4 respectively. Both Figures illustrate how the available pasture at given time varies when grazing rate varies. The grazing rate could be between 10 and 18 kg DM cow^{-1} (Personal communication with Expert). In this study, grazing rate value of 12 $\text{kgDM day}^{-1}\text{cow}^{-1}$ was considered as basic scenario.

From Fig. 14, Zr values of 16–18 $\text{kgDM day}^{-1}\text{cow}^{-1}$ could lead to good performance with stocking rate of 3 cow ha^{-1} . During practical grazing management, the performance can be improved by increasing stocking rate during the period when there is more available pasture. For instance, for cows with Zr of 16 $\text{kgDM day}^{-1}\text{cow}^{-1}$, more than 3 cows per ha can be allowed to graze during July and August (see Fig. 14). Similarly, Fig. 15 points out that Sr value of 4 could perform well for cows that have average Zr of 12 $\text{kgDM day}^{-1}\text{cow}^{-1}$.

The sensitivity analysis enabled to understand how the variation in

Zr impacts management of a continuous grazing system. Therefore, it could contribute to improve the knowledge based grazing management. According to Van de Goor (2016), there is a limitation of knowledge regarding pasture production during grazing season. In some cases of continuous grazing system, often there is low stocking rate but long grazing period. It should be noted that there is pasture losses during grazing due to trampling and covering by faeces. This fact should be taken into consideration during managing dynamic stocking rate.

Improving the management of grazing system is important for Swedish dairy farms as there are some challenges in relation to grazing pasture (Kivling, 2012), due to increased labour demand for additional management activities in dairy farming. In addition, especially in case of using a fixed milking parlour, milk yield could reduce due to unpredictable feed quality and decreased MF as cows could be less voluntary to walk to the milking facility when they graze at farther distance from the robots. Therefore, introducing pasture-based mobile AMS could play important role if augmented with efficient grazing management.

Table 6

Results of sensitivity analysis for varying Zr values.

Zr ($\text{kgDM cow}^{-1}\text{day}^{-1}$)	FMF (LkgDM^{-1})	MDcalf ($\text{L cow}^{-1}\text{day}^{-1}$)	MY (milked) ($\text{L cow}^{-1}\text{day}^{-1}$)	DMY(total)** ($\text{L cow}^{-1} \text{day}^{-1}$)	CMY*** (L cow^{-1})	CMYh*** (L ha^{-1})
10	1.23	7	9	16	1106	2948
12	1.25	7	12	19	1445	3967
16	1.32	8	17	25	2101	6303
18	1.71	8	28	36	3433	10,300

*-in addition to grazing, about 3 kg cow day concentrate (supplement) has been considered; **-including consumption by calf; ***-at the end of grazing period.

Table 7
Results of sensitivity analysis for varying MF and DM_{Y2} values.

MF	DMY (L cow ⁻¹ day ⁻¹)*		
	DMY ₂ = 20	DMY ₂ = 25	DMY ₂ = 30
1	14	17	21
2	20	25	30
3	23	28	34
4	24	30	36
5	25	31	37
6	25	31	37

*-daily milk yield including consumption by calf

3.2. Milking and milk yield characteristics

In this study milk yield estimated based on values of MF, animal feed intake, FMF, as well as Sr. Fig. 16 illustrates the cumulative milk yield for conditions where Zr, FMF, Sr were 16 kgDM cow⁻¹, 1.32 L kgDM⁻¹, and 3 cow ha⁻¹ respectively. For this condition, the estimated cumulative milk yield values at the end of grazing period were 2101 L cow⁻¹ and 6303 L ha⁻¹ respectively.

The detailed sensitivity analysis result is provided in Table 6. Considering 3 kg day⁻¹cow⁻¹ and by varying Zr and FMF values (see Table 6), milk yield values at different levels were estimated. The average daily milk yield (including calf feeding), varied from 16 to 36 L day⁻¹ cow⁻¹ as Zr varied from 10 to 18 kg day⁻¹cow⁻¹. Assuming constant average daily milk yield over the grazing period under consideration (15th May –15th September), the cumulated milk yield values were also determined at two levels i.e. per cow and per hectare of grazing area (see Table 6). At the end of grazing period, the cumulative milk yield per cow varied from 1106 to 3433 L day⁻¹ cow⁻¹ while, at hectare level, it varied from 2948–10300 L day⁻¹ha⁻¹.

In this modelling process, it was assumed that a cow consumes about 3 kg concentrate feed daily. In some case of pasture based dairy system, 0–300 g has been noticed to be effective with AMS and often 3–4 kg cow⁻¹day⁻¹ of concentrate is recommended in AMS (Bach and Cabrera, 2017) even though a maximum of 8.4 kg cow⁻¹day⁻¹ could be supplied.

Milk yield depends also on MF. According to Kivling (2012), the MF is about 2.3 per day for unrestricted grazing cows and 2.5–2.8 milkings per day for cows with restricted grazing. Since there was no recorded data in the current study, sensitivity analysis was conducted using eq (10a) and varying daily milk yield corresponding to twice-daily milking practice (see Table 7). In this case three DM_{Y2} values were considered i.e. 20, 25, and 30 L day⁻¹cow⁻¹. The analysis indicates that on average, in dairy farms which have DM_{Y2} value of about 30 L day⁻¹cow⁻¹ could provide more yield as MF increases to 3 or 4 milkings per day.

In grazing dairy system with AMS, MF is often 3–4 times per day

(Ketelaar-de Lauwere et al., 1999). Studies indicated that increasing MF from twice-daily to thrice-daily could increase milk yield by 10–21% (Hart et al., 2013; Stelwagen, 2001). As MF increases, feed consumption per day increases. For instance, Hart et al (2013) discussed that, feed intake as dry mater (DM) of cows in Canada increased from 23.6 kg to 24.7 kgDM day⁻¹cow⁻¹ when MF increased from twice daily to thrice daily, i.e. about an increase of 4.7%. Forage consumption of cows varies for different animal breeds. Feed intake and concentrate supply varies also along the lactation period. Concentrate intake is high during lactation peak i.e. from 3 until 14 weeks (Bach and Cabrera, 2017).

Using eq(11) and Simulink model, the sensitivity analysis was also done to understand the how weekly milk yield varies along lactation period for varying peak milk yield. The weekly yield increased from first week to peak week (5th week) by about 17%. From peak week to end of the grazing period (24th week of lactation), the weekly yield decreased by about 36%. Similarly, the weekly yield decreased from first week of lactation to end of grazing period by 25%. For instance, if daily milk yield during peak week is 40 L day⁻¹cow⁻¹, the estimated WMY values at 1st, 5th, and 24th weeks of lactation were 238, 280, and 179 L cow⁻¹week⁻¹ respectively (see Fig. 17). In this case, it was assumed that lactation starts in the first week of April. Fig. 17 depicts only the time till the end of grazing season.

In early lactation, a cow could produce up to 50 L day⁻¹ with feed intake of 1 kgDM to produce about 1.6 L of milk. In late lactation, the yield could be reduced by about 50% and 1 kg of DM could produce about 1.4 L milk (Albertamilk, 2020).

3.3. MVM and alternative milk marketing

Fig. 18 presents the simulation results for estimation milk demand by local customers and quantity delivered to supermarket. For this illustration purpose, only 12 local customers, with average milk demand of 2 L day⁻¹ each, were considered. In actual case, different customers could have different milk demand. Considering milk yield (6303 L ha⁻¹) corresponding to Zr and Sr values of 16 and 3 respectively, at the end of grazing period, CMDlc and CMsm were estimated to be 2952 L and 3351 L respectively.

In this study, milk supply priority was set to be: (i) feeding the calves; (ii) supply to local customers via MVM; and (iii) delivery to supermarket. Accordingly, the quantity to be supplied to supermarket highly depends on size of the dairy farm and amount sold via MVM. Table 8 presents how CMsm varies with Zr values and related milk yield per hectare. When Zr is 10, there would not be enough milk to be delivered to supermarket. On the other hand, when Zr is 18, a cumulative amount of about 7347 L could be supplied to supper market over the whole grazing period.

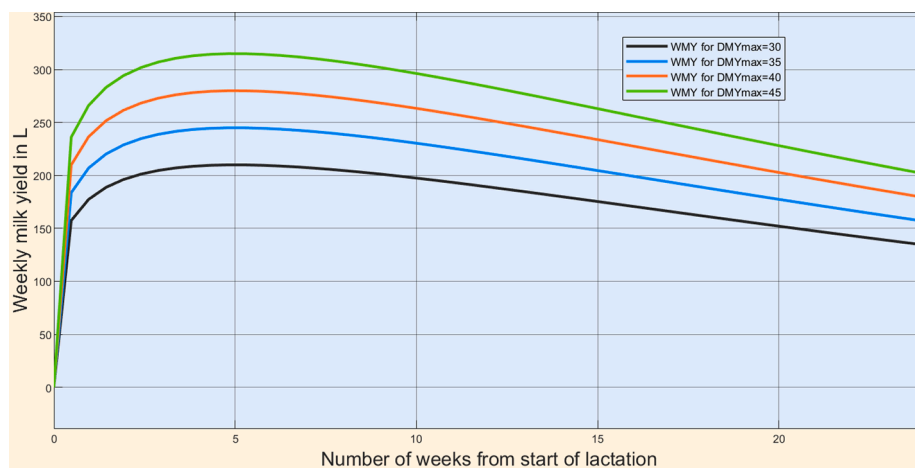

Fig. 17. Sensitivity analysis: influence of varying peak milk yield along lactation (grazing period).

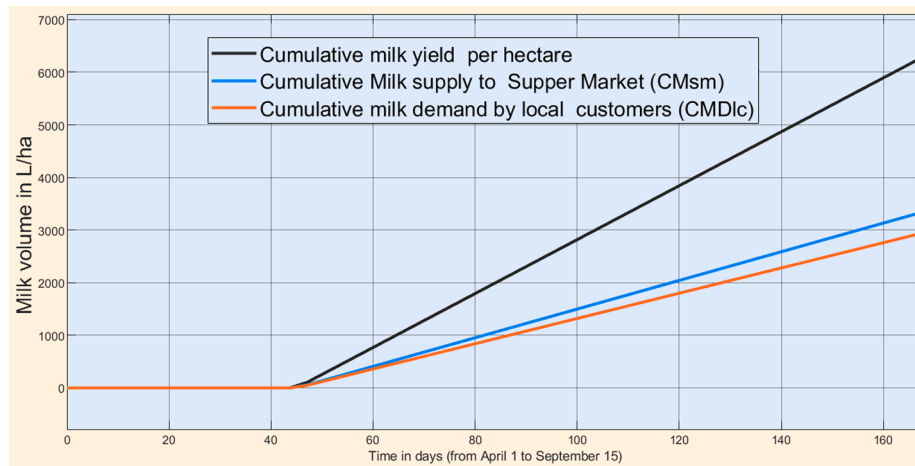

Fig. 18. Simulated cumulative milk yield per ha, demand by local customers and super market. The figure is related to the case of $Z_r = 16$ and $S_r = 3$ were considered.

Table 8

Results of sensitivity analysis local milk demand for varying Z_r values.

Z_r	FMF (L kgDM ⁻¹)	MY* (L cow ⁻¹ day ⁻¹)	CMY (L cow ⁻¹)	CMYh (L ha ⁻¹)	CMDlc (L)	CMsm (L)
10	1.23	9	1106	2948	2952	0
12	1.25	12	1445	3967	2952	1015
16	1.32	17	2101	6303	2952	3351
18	1.71	28	3433	10,300	2952	7347

*-daily milk for marketing i.e. milk yield excluding consumption by calf

Milk selling at farm via MVM should be managed well to avoid health risks. Therefore, on-farm milk pasteurization was considered in this study (see Section 2.1.3). Raw milk should be handled appropriately by both suppliers and purchasers. Unlike pasteurized milk, the risk of drinking raw milk is high. [Fechner et al \(2019\)](#) discussed that, due to its advantages, on-farm milk pasteurization has increasing trend. For instance, pasteurized milk can be feed to calves to reduce pathogens transmissions.

3.4. Further discussion

Grazing pasture improves sustainability of dairy system. Earlier studies indicated that pasture-based dairy farms have health and behavioural benefits for cows ([Shepley et al., 2017](#)). One of advantages of pasture-based dairy system is that longer photoperiod (about 18 h) increases daily milk yield by about 6.5% when compared with cows kept under ambient light (≤ 13 h of exposure) ([Stelwagen, 2001](#)). On the other hand, pasture is the cheapest source of feed for dairy farm ([Kerrisk, 2010](#); [Bach and Cabrera, 2017](#); [Lemaire, 2012](#)). In addition to reducing feed cost, pasture-based dairy system could reduce environmental impact from feed production, and methane (CH₄) emissions from long-term manure storage of housed dairy system. In a confined dairy system, CH₄ emissions from enteric fermentation and manure management are the main causes of greenhouse gas emission ([Aguirre-Villegas et al., 2017](#)). A well planned grazing system enables also to maintain biodiversity of open landscape ([Metera et al., 2010](#)).

Grazing increases animal performance ([Lemaire, 2012](#)). In the case of non-mobile AMS, once-daily milking method reduces stress and lameness by reducing the walking to and from the milking facility ([Stelwagen et al 2013](#)). Such challenge could be addressed by implementing a mobile AMS during grazing season. Pasture-based AMS could also facilitate the investigation of calf-cow-together practice. There is growing interest of consumers and farmers to promote cow-calf together as an alternative practice due to perception that it could have better cow

and calf health ([Busch et al; 2017](#)). Some studies indicated that there are expected advantages and drawbacks of cow-calf-together alternative ([Flower and Weary, 2001](#); [Asheim et al., 2016](#); [Gundersen, 2019](#)). These concerns deserve attention of researchers as it could affect the future competitiveness of dairy farms in the market ([Busch et al., 2017](#)).

Through promoting short supply chain, MVMs connects farmers and consumers, increase efficiency of resource utilization (energy, packaging, transportation, and other logistics services). This has environmental and socio-economic benefits. If it gets full attention and support from concerned stakeholders, MVM helps to transform the dairy sector of agriculture ([Dolezalova et al., 2014](#)). However, the use of MVMs should be augmented by operational guidelines including hygienic control ([Giacometti et al, 2013](#)).

In general, the current study could contribute more to the sustainability of dairy farm through promoting calf-cow-together and animal health, renewable energy production and use, biodiversity, reduction of milk loss, and increasing overall profitability. It is expected that DigiMilk simulation tool could be improved further and become an integrated decision making tool. It enables end users (dairy farms) to: simulate and understand pasture characteristics and provide support for grazing management; estimate milk yield and understand milking characteristics using mobile AMS; plan and manage on-field and off-field milk marketing processes; plan and manage resource consumption e.g. energy, water, labour etc.; estimate cost incurred, benefit gained, and decide on future budget or investment plans. Part 2 of this study will report part of DigiMilk model i.e. the detailed resources and economic assessment of pasture-based mobile AMS.

4. Conclusion

This study was initiated to develop the concept and multipurpose simulation model (DigiMilk model) for the investigation of pasture-based mobile automatic milking system (AMS) and option of milk marketing directly from grazing field, considering grazing condition in central Sweden. The model comprises the following major subsystems: Pasture yield and grazing characteristics; AMS Milking and milk yield characteristics; milk handling and marketing; and resource consumption; and economic assessment. This paper (Part-I) focused on the first three components while the remaining two subsystems have been addressed in Part-II of this paper.

DigiMilk model was built in MATLAB-Simulink environment. It was tested and evaluated using mainly secondary data and limited primary information acquired from a dairy farm in Sweden, where a continuous stocking system was assumed to be implemented from May 15 till September 15.

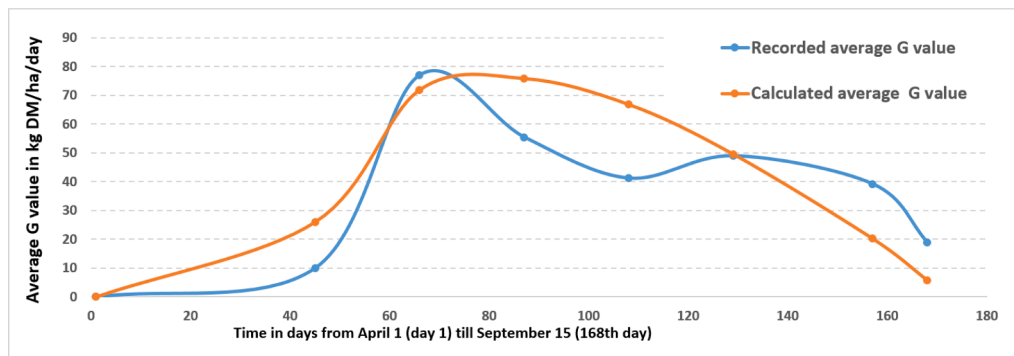

Fig. A1. Measured grass growth rate (G) value from Frankow-Lindberg (1989) and Calculated G value using equation (Cacho, 1993). The regression analysis was done and resulted in R^2 value of 0.721. From this Fig. A1, G_{max} was estimated to be 77 kgDM/ha/day.

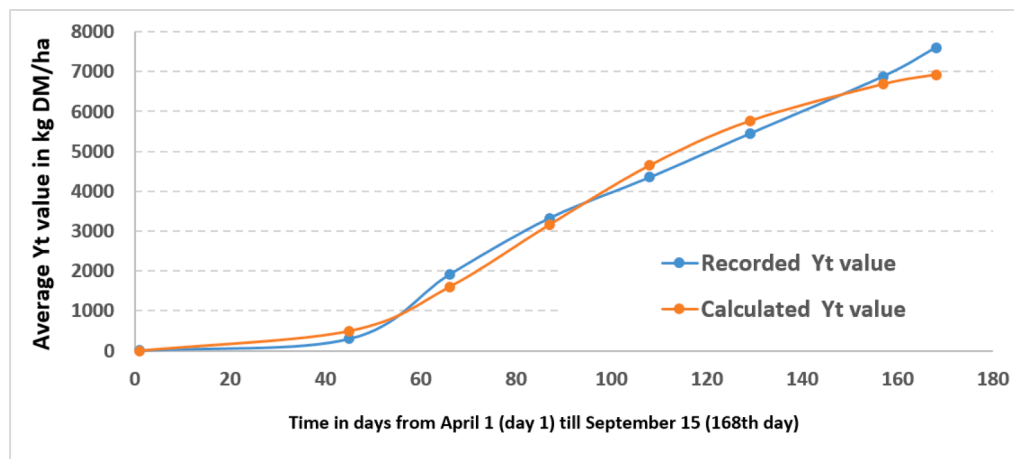

Fig. A2. Measured pasture yield (Yt) value from Frankow-Lindberg (1989) and Calculated Yt value using equation (Cacho, 1993). The regression analysis was done and resulted in R^2 value of 0.987. These comparison of recorded and calculated curves was used to determine parameters needed to model the pasture and grazing characteristics subsystem in the newly developed Simulink model. From Figs. A1 and A2, Y_{opt} was estimated to be 2850 kgDM ha^{-1} . From Fig. A2, Y_{max} was determined to be 8000 kgDM ha^{-1} (see Table 1).

Considering a maximum pasture growth rate of about 77 kgDM $day^{-1}ha^{-1}$ which occurs towards end of May, the accumulated average pasture yield, till end of grazing season (September 15) was estimated to be 6928 kgDM ha^{-1} . However, the potential maximum pasture yield from April to October was estimated to be 8000 kgDM ha^{-1} . The grazing rate varied from 12 to 18 kgDM $day^{-1}cow^{-1}$. The sensitivity analysis indicated that for cows which have an average grazing rate of 16–18 kgDM $day^{-1}cow^{-1}$, and a stocking rate of 3 cow ha^{-1} could lead to good performance of grazing management. Similarly, for cows with grazing rate of 12–14 kgDM $day^{-1}cow^{-1}$, stocking rate of 4 cow ha^{-1} could lead to good performance. During practical grazing management, the performance can be improved by increasing stocking rate during the period when there is more available pasture.

The model enabled to simulate the cumulative milk yield over the grazing season, the amount to be sold on-site using milk vending machine, and amount to be supplied to supermarket. In practice, the amount of milk to be supplied to supermarket depends total production capacity of the farm and amount sold using the milk vending machine.

In this study, multiple sensitivity analyses were successfully conducted to get more insights. Accordingly, the model has been both conceptually and technically proved to be effective. Its ability to provide more accurate simulation outputs could be improved with future work with more real data. In addition to its capacity to serve as an integrated decision making tool, DigiMilk model enables to have organized digital data that could be useful for future studies, for instance, to evaluate the environmental and/or economic performance of pasture-based dairy system with mobile AMS.

Declaration of Competing Interest

The authors declare that they have no known competing financial interests or personal relationships that could have appeared to influence the work reported in this paper. This research received no external funding.

Acknowledgment

The authors are grateful to Mr Mats Pehrsson, Head of Swedish Livestock Research Centre of SLU, for providing valuable information and expert discussions during the development of the model.

Appendix

See Figs. A1, A2.

References

- Agrawal, P., Narain, R., 2018. Digital supply chain management: An overview. *Mater. Sci. Eng.* 455, 1–6. <https://doi.org/10.1088/1757-899X/455/1/012074>.
- Aguirre-Villegas, H.A., Passos-Fonseca, T.H., Reinemann, D.J., Larson, R., 2017. Grazing intensity affects the environmental impact of dairy systems. *J. Dairy Sci.* 100, 6804–6821. <https://doi.org/10.3168/jds.2016-12325>.
- Albertamilk, 2020. How much feed does a cow need to produce 1 litre of milk? URL: <https://albertamilk.com/ask-dairy-farmer/how-much-feed-does-a-cow-need-to-produce-1-litre-of-milk/>. Accessed on August 3, 2020.
- Alibaba, 2020a. Automatic fresh milk vending machine. URL: https://www.alibaba.com/product-detail/bill-and-coin-acceptor-automatic-fresh_62026228903.html?spm=a2700.7724838.0.0.62c87a23TY6QhO. Accessed on August 3, 2020.
- Alibaba, 2020b. A small milk pasteurizer machine. URL: https://www.alibaba.com/product-detail/small-milk-pasteurizer-small-milk-pasteurizer_60692715931.html?spm=a2700.7724838.0.0.148b5f840ifrhR&s=p. Accessed on August 3, 2020.

- Asheim, L.J., Johnsen, J.F., Havrevoll, Ø., Mejdell, C.M., Grøndahl, A.M., 2016. The economic effects of suckling and milk feeding to calves in dual purpose dairy and beef farming. *Rev Agric Food Environ Stud* 97, 225–236. <https://doi.org/10.1007/s41130-016-0023-4>.
- Bach, A., Cabrera, V., 2017. Robotic milking: Feeding strategies and economic returns. *J. Dairy Sci.* 100, 7720–7728. <https://doi.org/10.3168/jds.2016-11694>.
- Busch, G., Weary, D.M., Spiller, A., von Keyserlingk, M.A.G., 2017. American and German attitudes towards cow-calf separation on dairy farms. *PLoS ONE* 1–20. <https://doi.org/10.1371/journal.pone.0174013>.
- Cacho, O.J., 1993. In: A practical equation for pasture growth under grazing. Wiley Online Library, pp. 387–394. <https://doi.org/10.1111/j.1365-2494.1993.tb01873.x>.
- Cooper, K., Parsons, D.J., 1999. An Economic Analysis of Automatic Milking using a Simulation Model. *J. Agric. Engng Res.* 1999 (73), 311–321.
- DeLaval, 2018. DelVal VMS™ V300, A system approach. Brochure of DeLaval. URL: <https://www.delaval.com/globalassets/inriver-resources/document/brochure/vms-v300-usa-brochure.pdf>. Accessed on August 2, 2020.
- Doležalova, H., Picha, K., Navratil, J., Bezemkova, A., 2014. Factors that influence the selling of milk through milk vending machines. *Acta Universitatis Agriculturae et Silviculturae Mendelianae Brunensis*. <https://doi.org/10.11118/actaun201462040641>.
- Drewry, J.L., Shutske, J.M., Trechter, D., Luck, B.D., Pitman, L., 2019. Assessment of digital technology adoption and access barriers among crop, dairy and livestock producers in Wisconsin. *Comput. Electron. Agric.* 165 (104960) <https://doi.org/10.1016/j.compag.2019.104960>.
- Fechner, K., Dreyman, N., Schimkowiak, S., Czerny, C.-P., Teitzel, J., 2019. Efficacy of dairy on-farm high-temperature, short-time pasteurization of milk on the viability of *Mycobacterium avium* ssp. *paratuberculosis*. *J. Dairy Sci.* 102, 11280–11290. <https://doi.org/10.3168/jds.2019-16590>.
- Flower, F.C., Weary, D.M., 2001. Effects of early separation on the dairy cow and calf: 2. Separation at 1 day and 2 weeks after birth. *Appl. Animal Behav. Sci.* 70, 275–284.
- Frankow-Lindberg, B.E., 1989. The effect of nitrogen application pattern on pasture yield, growth pattern, quality. Swedish University of Agricultural Sciences. Växtodling-9. ISSN 1100-1151. URL: <https://www.worldcat.org/title/kvavefordelning-till-betesvall-och-dess-effekter-pa-avkastning-tillvaxtmonster-och-kvalitet-the-effect-of-nitrogen-application-pattern-on-pasture-yield-growth-pattern-and-quality/oclc/66829246>.
- Giacometti, F., Bonilauri, P., Serraino, A., Peli, A., Amatiste, S., Arrigoni, N., Bianchi, M., Bilei, S., Cascone, G., Comin, D., Daminelli, P., Decastelli, L., Fustini, M., Mion, R., Petruzzelli, A., Rosmini, R., Rugna, G., Tamba, M., Tonucci, F., Bolzoni, G., 2013. Four-Year Monitoring of Foodborne Pathogens in Raw Milk Sold by Vending Machines in Italy. *J. Food Prot.* 76 (11), 1902–1907. <https://doi.org/10.4315/0362-028X.JFP-13-213>.
- Golfarelli, M., Rizzi, S., 2009. What-if Simulation Modeling in Business Intelligence. *Int. J. Data Warehousing Mining (IJDWM)* 5 (4), 24–43. <https://doi.org/10.4018/jdwm.2009080702>.
- Gundersen, S., 2019. Strategies for keeping cow and calf together in six European countries. Independent project work, Swedish University of Agricultural Sciences, Uppsala. <https://stud.epsilon.slu.se/15499/> accessed on June 1, 2020.
- Guzhva, O., 2013. Exercise pasture compared with production pasture in a part time grazing system with automatic milking. Examensarbete, Swedish University of Agricultural Sciences, Uppsala, Sweden. URL: https://stud.epsilon.slu.se/5653/7/guzhva_o_130611.pdf. Accessed on December 24, 2020.
- Hart, K.D., McBride, B.W., Duffield, T.F., DeVries, T.J., 2013. Effect of milking frequency on the behavior and productivity of lactating dairy cows. *J. Dairy Sci.* 96, 6973–6985. <https://doi.org/10.3168/jds.2013-6764>.
- Islam, M.R., Garcia, S.C., Clark, C.E.F., Kerrisk, K.L., 2015. Modelling Pasture-based Automatic Milking System Herds: System Fitness of Grazeable Home-grown Forages, Land Areas and Walking Distances. *Asian Australas J. Animal Sci.* 28 (6), 903–910. <https://doi.org/10.5713/ajas.14.0385>.
- Kerrisk, K., 2010. Management guidelines for pasture-based AMS farms. ISBN 978-0-9806008-0-3. URL: https://futuredairy.com.au/wp-content/uploads/2016/02/AMS_Pasture_Based_Guidelines_Web.pdf.
- Ketelaar-de Lauwere, C.C., Ipema, A.H., van Ouwerkerk, E.N.J., Hendriks, M.M.W.B., Metz, J.H.M., Noordhuizen, J.P.T.M., Schouten, W.G.P., 1999. Voluntary automatic milking in combination with grazing of dairy cows: Milking frequency and effects on behavior. *Appl. Animal Behaviour Sci.* 64, 91–109. [https://doi.org/10.1016/S0168-1591\(99\)00027-1](https://doi.org/10.1016/S0168-1591(99)00027-1).
- Kolver, E.S., Muller, L.D., 1998. Performance and Nutrient Intake of High Producing Holstein Cows Consuming Pasture or a Total Mixed Ration. *J. Dairy Sci.* 81, 1403–1411. [https://doi.org/10.3168/jds.S0022-0302\(98\)75704-2](https://doi.org/10.3168/jds.S0022-0302(98)75704-2).
- Lemaire, G., 2012. Intensification of animal production from grassland and ecosystem services: a trade-off. doi: <https://doi.org/10.1079/PAVSNNR20127012>.
- Lindmark-Månsson, H., Fonden, R., Petterson, H.-E., 2003. Composition of Swedish dairy milk. *Int. Dairy J.* 13, 409–425. [https://doi.org/10.1016/S0958-6946\(03\)00032-3](https://doi.org/10.1016/S0958-6946(03)00032-3).
- Lyons, N.A., Kerrisk, K.L., Garcia, S.C., 2014. Milking frequency management in pasture-based automatic milking systems: A review. *Livestock Sci.* 159, 102–116. <https://doi.org/10.1016/j.livsci.2013.11.011>.
- Metera, E., Sakowski, T., Stoniewski, K., Romanowicz, B., 2010. Grazing as a tool to maintain biodiversity of grassland – a review. *Animal Science Papers and Reports*, 28 (4):315-334. URL: https://www.researchgate.net/publication/285796177_Grazing_as_a_tool_to_maintain_biodiversity_of_grassland_-_a_review. Accessed on December 27, 2020.
- Pang, D., Krizsan, S.J., Sairanen, A., Nousiainen, J., Huhtanen, P., 2019. In: Modelling feed intake and milk yield responses to different grass ley harvesting strategies. Wiley. <https://doi.org/10.1111/gfs.12425>.
- Rodenburg, J., 2017. Robotic milking: Technology, farm design, and effects on workflow. *J. Dairy Sci.* 100, 7729–7738. <https://doi.org/10.3168/jds.2016-11715>.
- Ruelle, E., Shalloo, L., Wallace, M., Delaby, L., 2015. Development and evaluation of the pasture-based herd dynamic milk (PBHDM) model for dairy systems. *Eur. J. Agron.* 71, 106–114. <https://doi.org/10.1016/j.eja.2015.09.003>.
- Schuetz, C.G., Schausberger, S., Schrefl, M., 2018. Building an active semantic data warehouse for precision dairy farming. *J. Org. Comput. Electron. Commerce* 28 (2), 122–141. <https://doi.org/10.1080/10919392.2018.1444344>.
- Shepley, E., Bergeron, R., Vasseur, E., 2017. Daytime summer access to pasture vs. free-stall barn in dairy cows with year-long outdoor experience: A case study. *Appl. Animal Behav. Sci.* 192, 10–14. <https://doi.org/10.1016/j.applanim.2016.11.003>.
- Shortall, J., Shalloo, L., Foley, C., Sleator, R.D., O'Brien, B., 2016. Investment appraisal of automatic milking and conventional milking technologies in a pasture-based dairy system. *J. Dairy Sci.* 99, 7700–7713. <https://doi.org/10.3168/jds.2016-11256>.
- SLU, 2017. Resources at The Swedish Livestock Research Centre. Dairy cows. <https://www.slu.se/globalassets/ew/org/andra-enh/vh/lovsta/dokument/resources-at-slu-lovsta-march-2017-webb.pdf>.
- Smith, J.M., 2020. Getting value from artificial intelligence in agriculture. *Animal Prod. Sci.* 2020 (60), 46–54. <https://doi.org/10.1071/AN18522>.
- Stelwagen, K., 2001. Effect of Milking Frequency on Mammary Functioning and Shape of the Lactation Curve. *J. Dairy Sci.* 84(E. Suppl.):E204-E211.
- Stelwagen, K., Phyn, C.V.C., Davis, S.R., Guinard-Flament, J., Pomies, D., Roche, J.R., Kay, J.K., 2013. *Invited review*: Reduced milking frequency: Milk production and management implications. *J. Dairy Sci.* 96, 3401–3413. <https://doi.org/10.3168/jds.2012-6074>.
- Tse, C., Barkema, H.W., Devries, T.J., Rushen, J., Pajor, E.A., 2018. Impact of automatic milking systems on dairy cattle producers' reports of milking labour management, milk production and milk quality. *Animal* 12 (12), 2649–2656. <https://doi.org/10.1017/S1751731118000654>.
- Kivling, S., 2012. Effect of grazing and housing system on dairy cows' hygiene, claw and leg health. Master's Thesis, Swedish University of Agricultural Sciences. https://stud.epsilon.slu.se/5285/1/kivling_s_130215.pdf.
- Van de Goor, S., 2016. Improvement of calculation methods for net grassland production under different grassland utilization systems. Farming Systems Ecology Group, Wageningen University. <https://orgprints.org/id/eprint/30793/1/MSc%20thesis%20Stijn%20vd%20Goor.pdf>.